



nLIGHT's PFL IR provides a robust solution for materials processing applications. Designed to meet the highest standards of reliability and durability, the air-cooled system outputs a near diffraction limited beam at 1064nm.

The PFL platform integrates nLIGHT's industry-leading technologies to deliver a highly effective, pulsed fiber laser solution:

- Powered by Pearl™ single-emitter diode laser modules, which set the standard of excellence in high-performance, high-reliability diode lasers
- Leveraging Liekki™ fiber with proprietary Direct Nano-particle Deposition (DND) technology that provides high efficiency and minimizes photodarkening

nLIGHT's PFL platform provides plug and play integration with maintenance-free operation.

Features

- High peak power: >133kW
- Short pulse width: 1.5ns
- Powered by Pearl™ SE diode laser engine
- Liekki™ DND fiber technology
- CleanGate™ technology for optimal pulse train performance
- Simple, plug and play integration
- Air-cooled

Applications

- PV scribing
- Marking and engraving
- Trimming
- Micro-machining
- Precision drilling

Proven Performance

Typical Device Performance

Optical		NL-PFL-10-1064	NL- PFL-20-1064 <i>Alpha Release</i>
Mode of operation		Pulsed	
Polarization		Random	
Wavelength	nm	1064	
Nominal average power	W	10	20
Pulse width	ns	1.5	
Beam Quality	M ²	<1.3	
Peak Power	kW	133	167
Output Beam diameter(@1/e ²)	mm	<0.7	
Output beam divergence angle(full)	mrad	<7	
Pulse repetition rate	kHz	50	80
Electrical			
Input voltage	V _{DC}	24	
I _{max} (20C)	IDC	7	10
External AC/DC converter available as option			
Control		Analog / RS232	Analog / RS232
Mechanical			
Cooling method		Air	
Thermal			
Operating temperature	°C	0 to +40	
Storage temperature	°C	-20 to +60	
Relative Humidity	%	5 to 95	

Package Dimensions

Laser Head

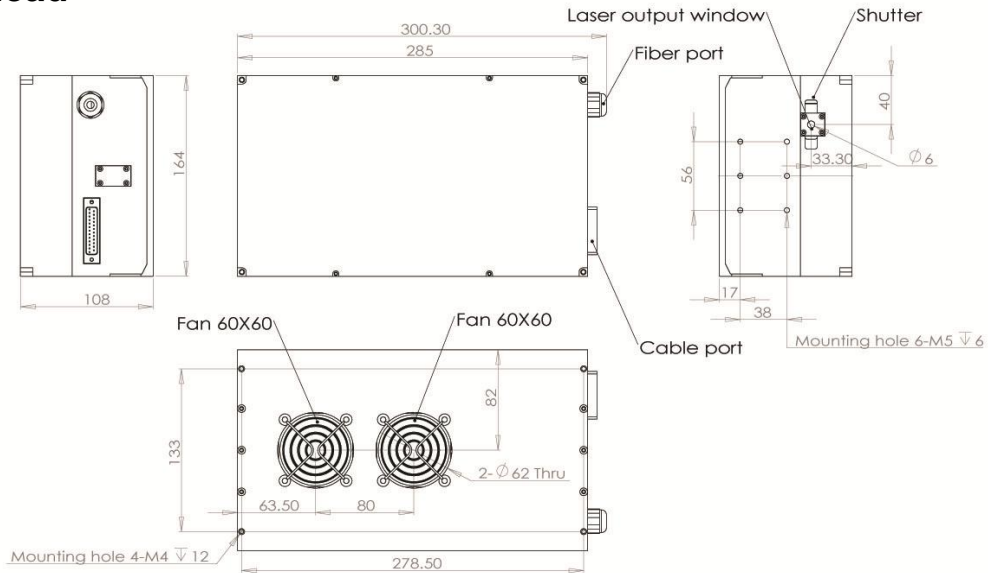

Driver

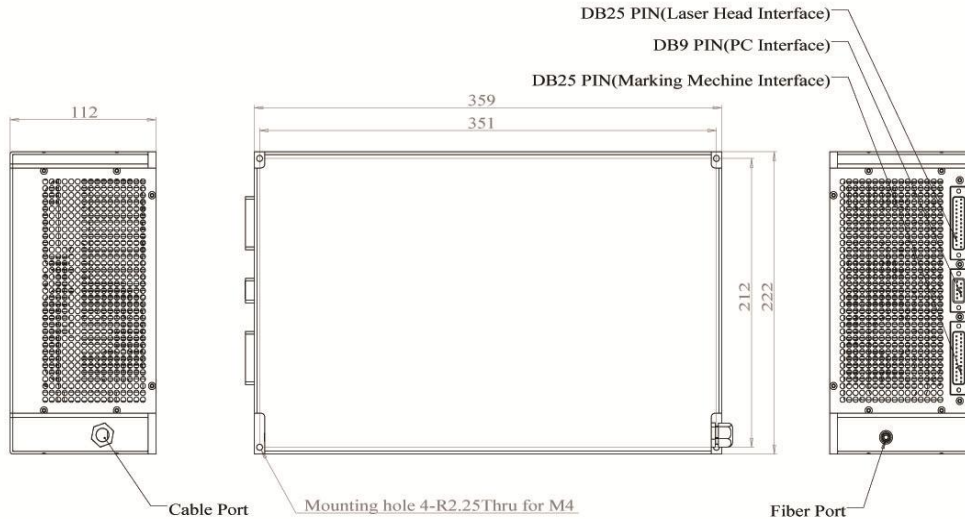

CFR Regulation

These components do not comply with the federal regulation (Title 21 CFR, Chapter 1, Subchapter J) as administered by the Center for Device and radiological Health. Purchaser acknowledges that their products must comply with these regulations before they can be sold to an end-use.

Copyright © 2008 nLIGHT. All rights reserved.

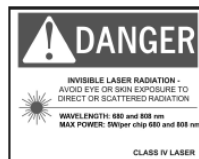

Notice

nLIGHT continually improves its products to provide our customers with outstanding quality and reliability. nLIGHT may make changes to specifications and product descriptions at any time, without notice. In addition, nLIGHT offers a limited warranty to ensure customer satisfaction. For complete details, please contact your nLIGHT sales representative.