



## *Alpha Release*

The Pearl Medical Series is optimized to meet the demanding requirements of consistent unit-to-unit performance with ease of integration. Standard features include a pilot beam, monitor photodiode and feedback tolerant design.

nLIGHT's proprietary single-emitter integration technology enables industry-leading efficiency and reliability, thus minimizing system footprint and maximizing doctor up-time.

The Pearl uses a revolutionary fiber technology, PowerCore™, which eliminates mode sensitivity to fiber motion, which optimizes consistency of light on skin performance.

## Features

- Patented nXLT™ diode protection for extended life
- Low-current, fault-tolerant architecture
- Industry-leading wall-plug efficiency
- PowerCore™ mode-stable fiber
- Plug and play compatibility with OptoTools™ DL system
- Electrically isolated housing

## Applications

- Acne Treatment
- BPH
- Dental
- Eye Surgery
- Hair Removal
- Leg Vein Treatment
- Surgical

## Proven Performance

## Typical Device Performance – Preliminary

Package		P10					P16				
<b>Optical</b>											
Wavelength	nm	810	980	1470/1530	1700	1908/1940	810	980	1470/1530	1700	1908/1940
Wavelength tolerance	nm	10	10	20	20	20	10	10	20	20	20
CW output power <sup>5</sup>	W	25	30	20	12	8	35	50	35	20	13
Fiber core diameter	µm	400	200/400	200/400	200/400	200/400	400	200/400	200/400	200/400	200/400
Beam divergence	NA <sup>1</sup>	0.22	0.22	0.22	0.22	0.22	0.22	0.22	0.22	0.22	0.22
Spectral width (FWHM)	nm	5	10	15	15	20	5	5	15	15	20
Slope efficiency <sup>5</sup>	W / A	5.5	5.5	4.0	2.5	1.5	8.5	8.5	7.0	4.0	2.0
<b>Electrical</b>											
Power conversion efficiency <sup>5</sup>	%	50	58	35	17	10	50	58	35	17	10
Threshold current	A	1.0	0.4	0.8	1.4	0.9	1.0	0.4	0.8	1.4	0.9
Operating current <sup>5</sup>	A	5.5	6.1	5.7	6.6	7.5	5.0	6.3	6.0	6.8	7.7
Operating voltage	V	9.0	8.3	11.1	11	10	14.5	13.2	18.5	17.6	16
Series resistance	Ω	0.1	0.2	0.3	0.3	0.5	0.2	0.3	0.5	0.5	0.9
Pilot Beam	mW	<1									
<b>Mechanical</b>											
Storage temperature range <sup>2</sup>	°C	-30 to +60									
Mass	gr	100	100	220	220	220	180	180	350	350	350
<b>Thermal</b>											
Thermal resistance <sup>3</sup>	°C / W	0.5	0.8	0.6	0.6	0.8	0.3	0.5	0.3	0.3	0.5
Operating temperature	°C	+15 to +35									
Wavelength temperature coefficient <sup>4</sup>	nm / °C	0.28	0.35	0.55	0.6	0.7	0.28	0.35	0.55	0.6	0.7
<b>Accessories</b>											
PPS™ OEM Diode Driver											
OptoTools™ DL System with DiodeSafe™											
Monitor Photo Diode											

<sup>1</sup> Numerical aperture (NA) is the sine of the half-angle encircling 90% of the optical energy from the fiber.

<sup>2</sup> A non-condensing environment is required for storage and operation.

<sup>3</sup> Thermal resistance is the diode junction temperature shift per incremental Watt of heat load.

<sup>4</sup> The wavelength temperature coefficient is the wavelength shift per °C change at the diode junction.

<sup>5</sup> If Pearl operated with an aiming beam these specification will be altered (consult factory for details)

## Package Dimensions

### P10 package

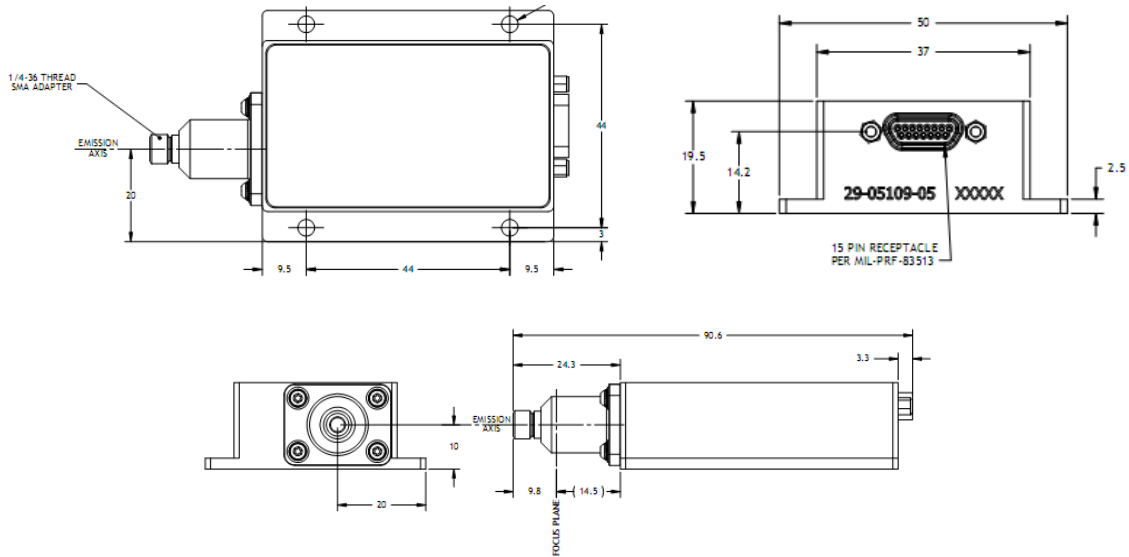

### P16 package

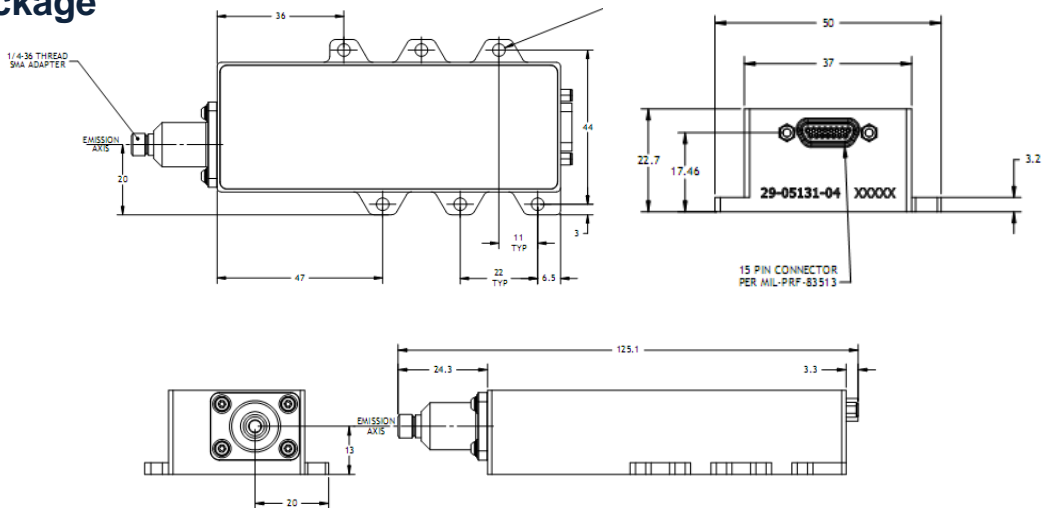

#### CFR Regulation

These components do not comply with the federal regulation (Title 21 CFR, Chapter 1, Subchapter J) as administered by the Center for Device and radiological Health. Purchaser acknowledges that their products must comply with these regulations before they can be sold to an end-use.

Copyright © 2008 nLIGHT. All rights reserved.



#### Notice

nLIGHT continually improves its products to provide our customers with outstanding quality and reliability. nLIGHT may make changes to specifications and product descriptions at any time, without notice. In addition, nLIGHT offers a limited warranty to ensure customer satisfaction. For complete details, please contact your nLIGHT sales representative.