



The Pearl™ Display and Entertainment Series is optimized to meet the demanding requirements of consistent unit-to-unit performance with ease of integration. The red wavelength spectrum can be tailored to reduce speckle.

nLIGHT's proprietary single-emitter integration technology enables industry-leading efficiency and reliability, thus minimizing system footprint and maximizing reliability.

The Pearl™ uses a revolutionary fiber technology, PowerCore™, which eliminates mode sensitivity to fiber motion and optimizes consistency of performance.

## Features

- Patented nXLT™ diode protection for extended life
- Low-current, fault-tolerant architecture
- Industry-leading wall-plug efficiency
- Field-replaceable, PowerCore™ mode-stable fiber
- Plug and play compatibility with OptoTools™ DL system
- Electrically isolated housing

## Applications

- Cinema Projection
- Large-Format Projection
- Home Theater Projection
- Laser TV
- Discothèque Light Shows
- Outdoor Light Shows

---

## Proven Performance

## Typical Device Performance

Package		P10	P16
<b>Optical</b>			
Wavelength	nm	639	
Wavelength tolerance	nm	± 4	
CW output power	W	4	7
Fiber core diameter	µm	400 or 600	
Fiber length	m	2.0, 3.0, 5.0	
Beam divergence	NA <sup>1</sup>	0.17	0.2
Spectral width (FWHM)	nm	4 <sup>5</sup>	
Slope efficiency	W / A	7.8	12.5
<b>Electrical</b>			
Power conversion efficiency	%	17	
Threshold current	A	0.65	
Operating current	A	1.3	
Operating voltage	V	21.1	33.8
Series resistance	Ω	1.4	2.2
<b>Mechanical</b>			
Storage temperature range <sup>2</sup>	°C	-40 to +80	
Mass	gr	220	350
<b>Thermal</b>			
Thermal resistance <sup>3</sup>	°C / W	0.9	0.6
Operating temperature <sup>2</sup>	°C	+15 to +25	
Wavelength temperature coefficient <sup>4</sup>	nm / °C	0.15	

<sup>1</sup> Numerical aperture (NA) is the sine of the half-angle encircling 90% of the optical energy from the fiber.

<sup>2</sup> A non-condensing environment is required for storage and operation.

<sup>3</sup> Thermal resistance is the diode junction temperature shift per incremental Watt of heat load.

<sup>4</sup> The wavelength temperature coefficient is the wavelength shift per °C change at the diode junction.

<sup>5</sup> Spectral width can be altered to reduce speckle

**Package Dimensions**

**P10 package**

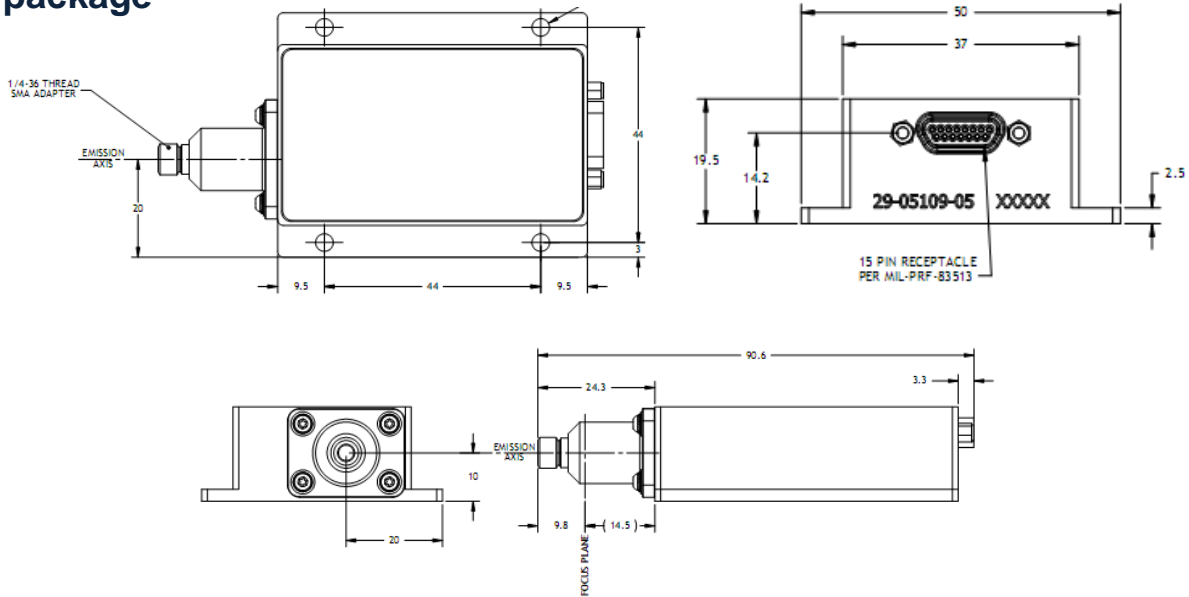

**P16 package**

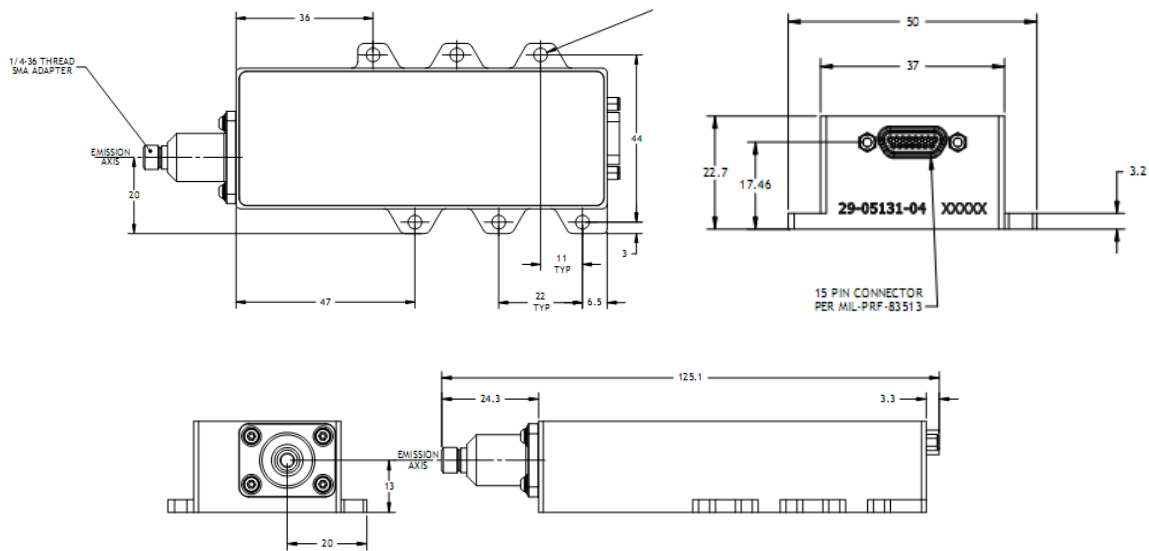

**CFR Regulation**

These components do not comply with the federal regulation (Title 21 CFR, Chapter 1, Subchapter J) as administered by the Center for Device and radiological Health. Purchaser acknowledges that their products must comply with these regulations before they can be sold to an end-use.

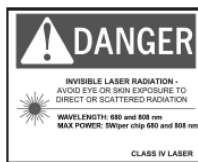

**Notice**

nLIGHT continually improves its products to provide our customers with outstanding quality and reliability. nLIGHT may make changes to specifications and product descriptions at any time, without notice. In addition, nLIGHT offers a limited warranty to ensure customer satisfaction. For complete details, please contact your nLIGHT sales representative.

Copyright © 2008 nLIGHT. All rights reserved.