

OptoTools PFL Green provides a robust solution for materials processing and photovoltaic applications. Designed to meet the highest standards of reliability and durability, the air-cooled system outputs a near diffraction limited beam at 532nm.

The OptoTools PFL platform integrates nLIGHT's industry-leading technologies to deliver a high-performance pulsed fiber laser solution:

- Powered by Pearl™ single-emitter diode laser modules, which set the standard of excellence in high-performance, high-reliability diode lasers
- Leveraging Liekki™ fiber with proprietary Direct Nano-particle Deposition (DND) technology that provides high efficiency and minimizes photodarkening

nLIGHT's PFL platform provides plug and play integration with maintenance-free operation.

Features

- High peak power: >40kW
- Short pulse width: 1.5ns
- *Powered by Pearl™* SE diode laser engine
- Liekki™ DND fiber technology
- Simple, plug and play integration
- Air-cooled

Applications

- PV scribing
- PV edge deletion
- Marking and engraving
- Trimming
- Micro-machining
- Precision drilling

Proven Performance

Typical Device Performance

Optical		NL-PFL-3-532	NL-PFL-5-532
Mode of operation		Pulsed	
Polarization		Linear / Horizontal	
Wavelength	nm	532	
Nominal average power	W	3	5
Pulse width	ns	1.5	
Beam quality	M ²	1.3	
Peak power	kW	40	67
Output beam diameter (@ 1/e ²)	mm	0.6	
Output beam divergence angle(full)	mrاد	5	
Pulse repetition rate	kHz	50	
Electrical			
Operating voltage	V _{AC}	200-240	
AC frequency	f _{AC}	50-60	
Control		Analog / RS232	
Mechanical			
Cooling method		Air	
Thermal			
Operating temperature	°C	0 to +40	
Storage temperature	°C	-20 to +60	
Relative humidity	%	5 to 95	

Package Dimensions

Driver

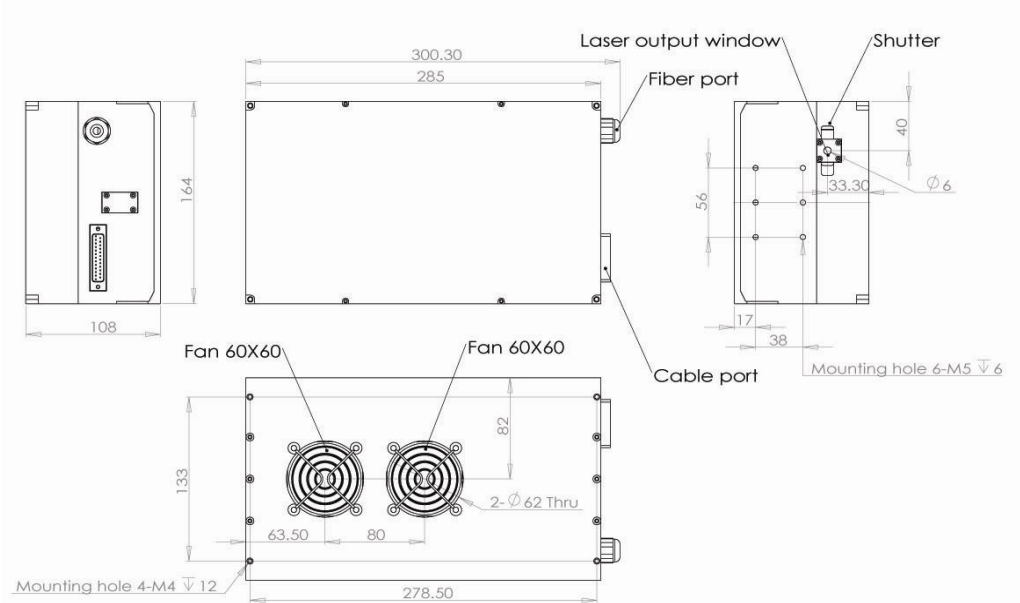

Head

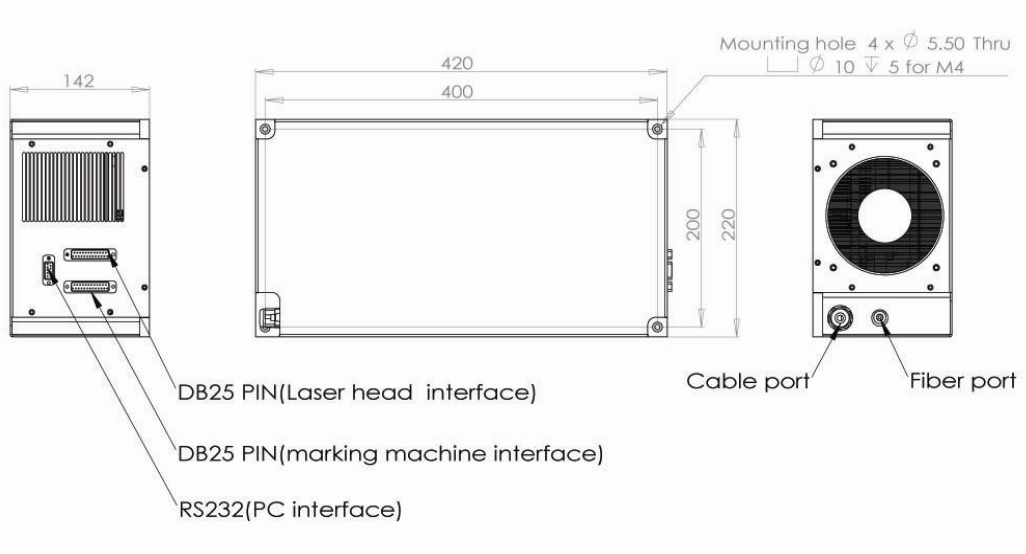

CFR Regulation

These components do not comply with the federal regulation (Title 21 CFR, Chapter 1, Subchapter J) as administered by the Center for Device and radiological Health. Purchaser acknowledges that their products must comply with these regulations before they can be sold to an end-use.

Copyright © 2008 nLIGHT. All rights reserved.



Notice

nLIGHT continually improves its products to provide our customers with outstanding quality and reliability. nLIGHT may make changes to specifications and product descriptions at any time, without notice. In addition, nLIGHT offers a limited warranty to ensure customer satisfaction. For complete details, please contact your nLIGHT sales representative.