



OptoTools low power CWFL provides a robust, highly reliable offering for material processing applications. The air-cooled design delivers a near-diffraction limited beam with WPE up to 25%.

The OptoTools CWFL platform integrates the best of nLIGHT's industry-leading technologies to deliver a highly effective, low power fiber laser solution:

- Leveraging Liekki™ fiber with proprietary Direct Nano-particle Deposition (DND) technology that provides high efficiency and minimizes photodarkening

Features

- Power up to 30W
- Modulation speed up to 50kHz
- Liekki™ DND fiber technology
- Simple, plug and play integration
- Air-cooled

Applications

- Marking and engraving
- Precision micro-welding
- Soldering and bonding
- Micro-machining

Proven Performance

Typical Device Performance

Optical		NL-CWL-10-1075	NL-CWL-20-1075	NL-CWL-30-1075
Mode of operation		CW		
Polarization		Random		
Wavelength	nm	1090 ±10		
Nominal output power	W	10	20	30
Output power tuning	%	10-100		
Output power stability	%	<1		
Red pilot light		Yes		
Beam delivery				
Beam quality		1.3	1.5	1.5
Beam diameter	mm	5		
Divergence	mrاد	0.4		
Beam pointing	degree	0.5		
Electrical				
Operating voltage, (DC)	Vdc	9	12	14
Maximum operating current	Idc	<14A		
Amplitude modulation	kHz	50		
Repetition rate	kHz	0 - 50		
Duty ratio	%	5-95	10-90	
AC/DC converter available upon request				
Mechanical				
Output fiber length	m	5		
Reinforced fiber cable diameter	mm	6		
Minimum cable bend radius	mm	75		
Collimator Dimensions*	mm	Φ14X125	Φ14X133	
Weight	kg	4	6	
Cooling method		Air cooled		
General condition				
Operating temperature	°C	+5 to +35		
Storage temperature	°C	-20 to +70		
Relative Humidity	%	5 to 95		

*Custom collimators available upon request.

Package Dimensions

30W Model

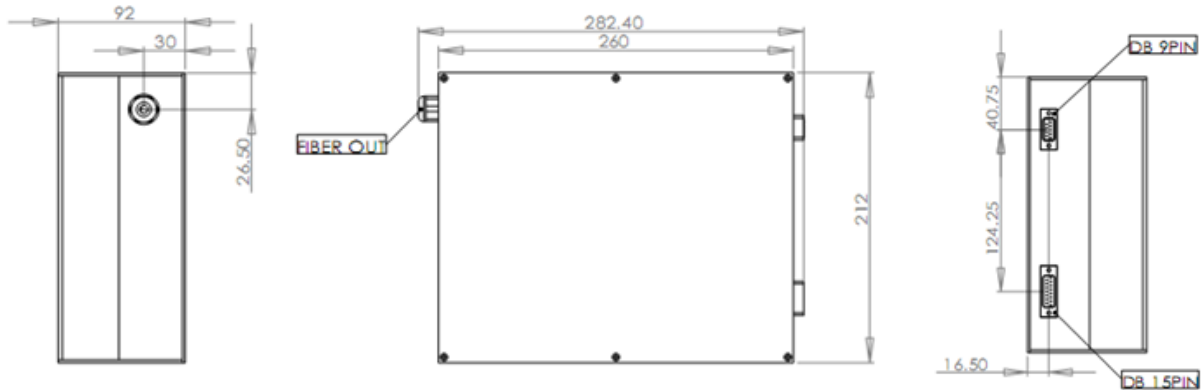

10W/20W Models

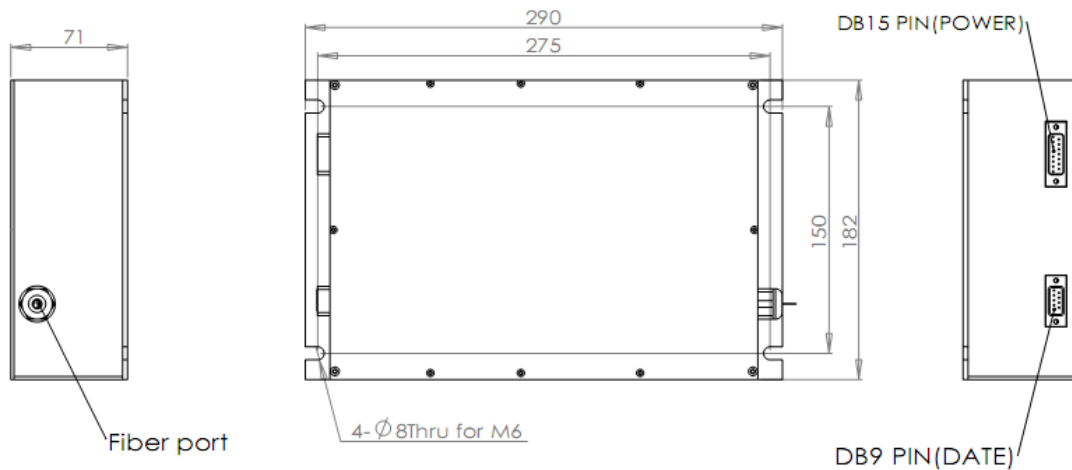

CFR Regulation

These components do not comply with the federal regulation (Title 21 CFR, Chapter 1, Subchapter J) as administered by the Center for Device and radiological Health. Purchaser acknowledges that their products must comply with these regulations before they can be sold to an end-use.

Copyright © 2008 nLIGHT. All rights reserved.

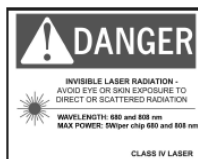

Notice

nLIGHT continually improves its products to provide our customers with outstanding quality and reliability. nLIGHT may make changes to specifications and product descriptions at any time, without notice. In addition, nLIGHT offers a limited warranty to ensure customer satisfaction. For complete details, please contact your nLIGHT sales representative.