



nLIGHT's nanosecond pulsed fiber laser, the PFL250™ IR provides a robust solution for materials processing and photovoltaic applications. Designed to meet the highest quality and reliability standards, the air-cooled system outputs a near diffraction limited beam at 1064nm. PFL250™ IR provides plug and play integration with maintenance-free operation.

The PFL250™ platform integrates nLIGHT's industry-leading technologies to deliver a high-performance pulsed fiber laser solution:

- Powered by Pearl™ single-emitter diode laser modules, which set the standard of excellence in high-performance, high-reliability diode lasers
- Leveraging LIEKKI™ fiber with proprietary Direct Nano-particle Deposition (DND) technology that provides high efficiency and minimizes photodarkening

Features

- High peak power
- Short pulse width: <1.5 ns
- Powered by Pearl™ SE diode laser engine
- LIEKKI™ DND fiber technology
- Plug and play integration
- Air-cooled

Applications

- PV scribing
- PV edge deletion
- Marking and engraving
- Ablation
- Trimming
- Micro-machining
- Precision drilling

Proven Performance

Typical Device Performance

Optical		NL-PFL250-1064		
		Min	Typ	Max
Mode of operation		Pulsed		
PER (polarization extinction ratio)	dB	20		
Wavelength	nm	1064		
Average power	W	20		
Operating power range	%	10 - 100		
Pulse width	ns	0.7		1.5
Pulse repetition rate	kHz	80 – 120 or 150 - 300		
Beam quality	M ²	1.2		
Pulse energy	μJ	120		
Average power stability (8 hrs)	%	2		
Electrical				
DC Operating voltage	V	24		
DC Operating current	A	< 13		
Control		Analog / RS232		
Mechanical				
Cooling method		Air		
Thermal				
Operating temperature, non-condensing	°C	10 - 40		
Storage temperature, non-condensing	°C	-20 - 70		

Package Dimensions

Laser Head

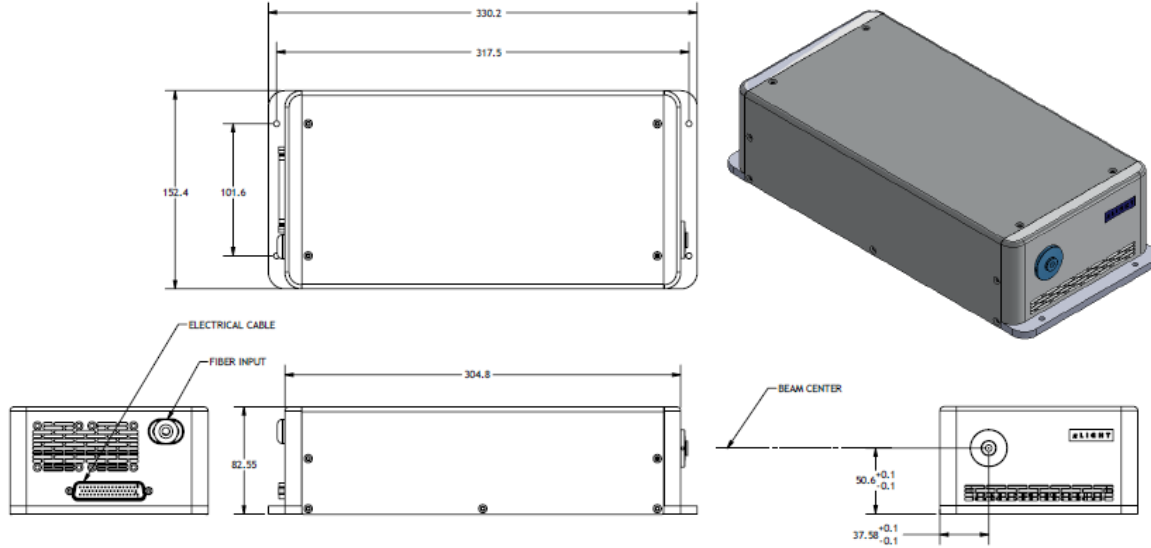

Driver

