



The Pearl solid-state laser pump series is designed to maximize fundamental mode extraction from end-pumped lasers. Disk and slab laser geometries benefit when long-term mode stability and beam quality are critical.

These pump lasers use a revolutionary fiber technology, PowerCore™, which delivers high-brightness, Gaussian or top-hat pump profiles to maximize overlap with the TEM<sub>00</sub> cavity mode for efficient brightness conversion to 1 μm. The industry-leading efficiency of these pump sources is enabling compactness, reliability and simplified cooling for the next generation of solid-state laser systems. Pearl's embedded nXLT™ single-emitter technology is resetting the benchmark for high-brightness semiconductor laser reliability.

## Features

- Patented nXLT™ diode protection for extended life
- Low-current, fault-tolerant architecture
- Industry-leading wall-plug efficiency >50%
- Field-replaceable, PowerCore™ mode-stable fiber
- Plug and play compatibility with OptoTools™ DL system
- Electrically isolated housing

## Applications

- Rod Pumping
- Disk Pumping
- Slab Pumping

## Proven Performance

## Typical Device Performance

| Package   |         | P10                | P16               |
|---|---------|--------------------|-------------------|
| <b>Optical</b>                                  |         |                    |                   |
| Wavelength                                      | nm      | 80x / 88x / 9xx    |                   |
| Wavelength tolerance                            | nm      | ± 3                |                   |
| CW output power                                 | W       | 50 / 60 / 70       | 100 / 110 / 120   |
| Fiber core diameter                             | µm      | 400, 600 @ 0.16NA  | 400, 600 @ 0.16NA |
| Fiber length                                    | m       | 2.0, 3.0, 5.0      |                   |
| Slope efficiency                                | W / A   | 10.5               | 17                |
| <b>Electrical</b>                               |         |                    |                   |
| Power conversion efficiency                     | %       | 50 / 54 / 58       |                   |
| Threshold current                               | A       | 1.0 / 1.0 / 0.6    |                   |
| Operating current                               | A       | 5.8                | 7.0               |
| Operating voltage                               | V       | 17                 | 28                |
| Series resistance                               | Ω       | 0.3                | 0.4               |
| <b>Mechanical</b>                               |         |                    |                   |
| Storage temperature range <sup>2</sup>          | °C      | -40 to +80         |                   |
| Mass  | gr      | 100                | 180               |
| <b>Thermal</b>                                  |         |                    |                   |
| Thermal resistance <sup>3</sup>                 | °C / W  | 0.4                | 0.3               |
| Operating temperature <sup>2</sup>              | °C      | +15 to +35         |                   |
| Wavelength temperature coefficient <sup>4</sup> | nm / °C | 0.28 / 0.31 / 0.33 |                   |
| <b>Accessories</b>                              |         |                    |                   |
| Monitor Photo Diode                             |         |                    |                   |
| PPS™ OEM Diode Driver                           |         |                    |                   |
| OptoTools™ DL System with DiodeSafe™ Protection |         |                    |                   |
| Optional Pilot beam (640nm)                     |         |                    |                   |

<sup>1</sup> Numerical aperture (NA) is the sine of the half-angle encircling 90% of the optical energy from the fiber.

<sup>2</sup> A non-condensing environment is required for storage and operation.

<sup>3</sup> Thermal resistance is the diode junction temperature shift per incremental Watt of heat load.

<sup>4</sup> The wavelength temperature coefficient is the wavelength shift per °C change at the diode junction.

**Package Dimensions**

**P10 package\***

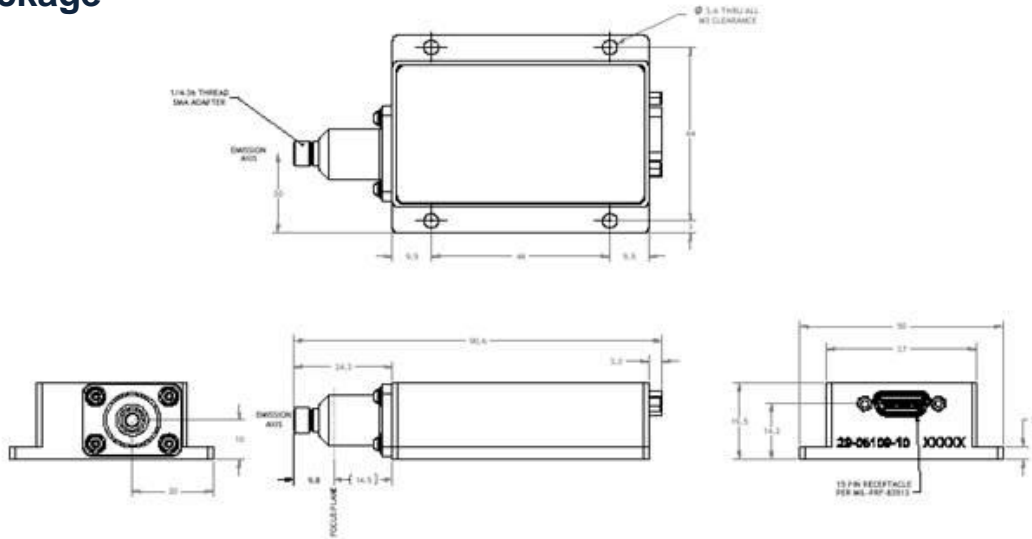

**P16 package**

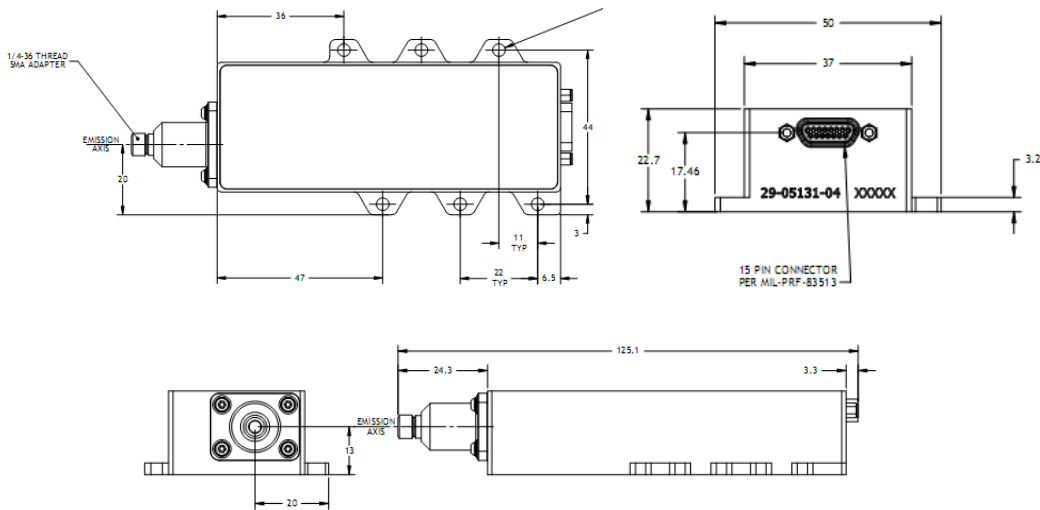

\* 800um fiber 0.13NA configuration increases the length of P10 Package 10.06 mm

**CFR Regulation**

These components do not comply with the federal regulation (Title 21 CFR, Chapter 1, Subchapter J) as administered by the Center for Device and radiological Health. Purchaser acknowledges that their products must comply with these regulations before they can be sold to an end-use.

Copyright © 2008 nLIGHT. All rights reserved.



**Notice**

nLIGHT continually improves its products to provide our customers with outstanding quality and reliability. nLIGHT may make changes to specifications and product descriptions at any time, without notice. In addition, nLIGHT offers a limited warranty to ensure customer satisfaction. For complete details, please contact your nLIGHT sales representative.