



The Pearl Materials Processing Series is optimized to meet the demanding industrial requirements of continuous performance with ease of integration.

nLIGHT's proprietary single-emitter integration technology enables industry-leading efficiency and reliability, thus minimizing system footprint and maximizing reliability.

These pump lasers use a revolutionary fiber technology, PowerCore™, which eliminates mode sensitive to fiber motion, which maximizes consistency of light on part performance.

## Features

- Patented nXLT™ diode protection for extended life
- Low-current, fault-tolerant architecture
- Industry-leading wall-plug efficiency >50%
- PowerCore™ mode-stable fiber
- Plug and play compatibility with OptoTools™ DL system
- Electrically isolated housing

## Applications

- Plastic Welding
- Soldering
- ACF Bonding
- PV Annealing
- FPD Annealing
- Marking

---

## Proven Performance

## Typical Device Performance

Package		P10	P16
<b>Optical</b>			
Wavelength	nm	810 / 9xx	
Wavelength tolerance	nm	± 10	
CW output power	W	Up to 40 / 60	Up to 80 / 110
Fiber core diameter	µm	400-600 / 200-600	
Beam divergence	NA <sup>1</sup>	0.17	0.18
Slope efficiency	W / A	8.5	14.8
Pilot Beam (640nm)	mW	< 1	
<b>Electrical</b>			
Power conversion efficiency	%	> 50 / > 58	
Threshold current	A	1.0 / 0.6	
Operating current	A	5.8	7.0
Operating voltage	V	14.5	23.5
Series resistance	Ω	0.2	0.4
Pilot Beam Drive Requirements		1.0A and 2.2V	
<b>Mechanical</b>			
Storage temperature range <sup>2</sup>	°C	-40 to +80	
Mass	g	100	180
<b>Thermal</b>			
Thermal resistance <sup>3</sup>	°C / W	0.4	0.3
Operating temperature	°C	+20 to +35	
Wavelength temperature coefficient <sup>4</sup>	nm / °C	0.28 / 0.33	
<b>Accessories</b>			
Line Generator Optic Modules Collimator and Spot Generator Optic Modules Monitor Photo Diode PPS™ OEM Diode Controller OptoTools™ DL System with DiodeSafe™ protection			

<sup>1</sup> Numerical aperture (NA) is the sine of the half-angle encircling 90% of the optical energy from the fiber.

<sup>2</sup> A non-condensing environment is required for storage and operation.

<sup>3</sup> Thermal resistance is the diode junction temperature shift per incremental Watt of heat load.

<sup>4</sup> The wavelength temperature coefficient is the wavelength shift per °C change at the diode junction.

## Package Dimensions

### P10 package

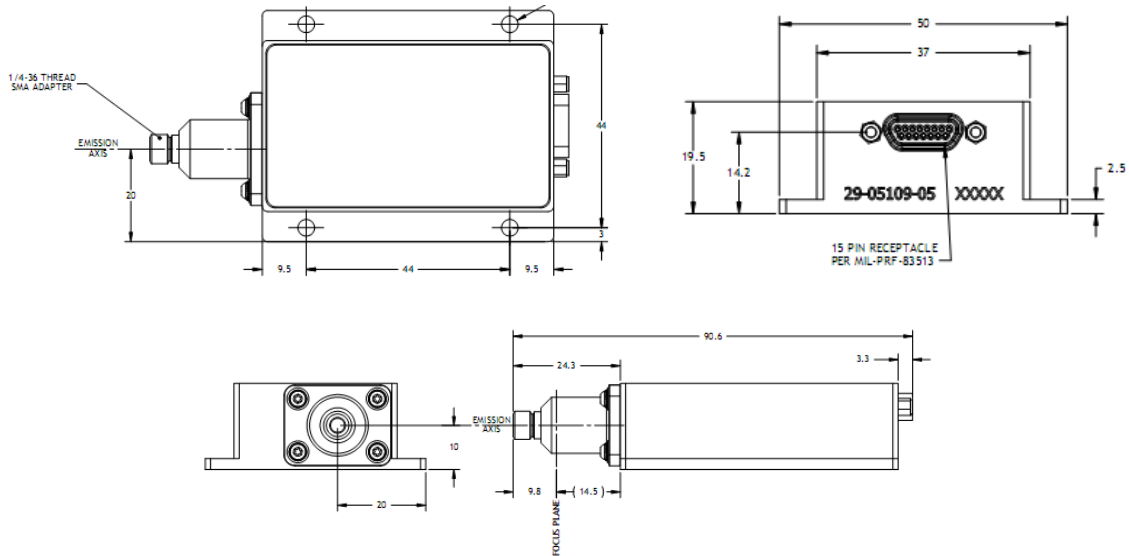

### P16 package

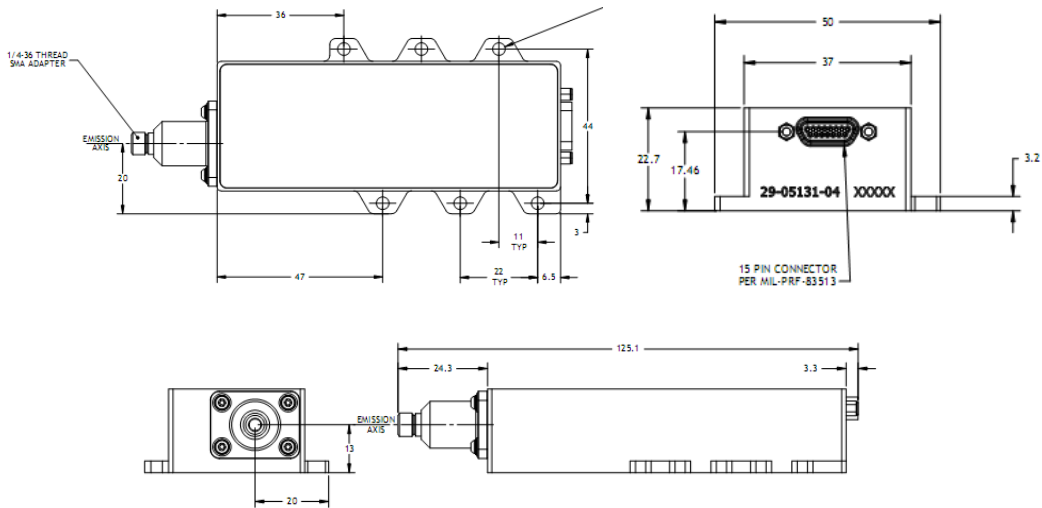

#### CFR Regulation

These components do not comply with the federal regulation (Title 21 CFR, Chapter 1, Subchapter J) as administered by the Center for Device and radiological Health. Purchaser acknowledges that their products must comply with these regulations before they can be sold to an end-use.

Copyright © 2008 nLIGHT. All rights reserved.

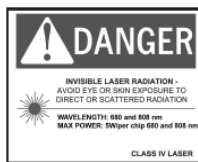

#### Notice

nLIGHT continually improves its products to provide our customers with outstanding quality and reliability. nLIGHT may make changes to specifications and product descriptions at any time, without notice. In addition, nLIGHT offers a limited warranty to ensure customer satisfaction. For complete details, please contact your nLIGHT sales representative.