



nLIGHT's Cascades™ vertical array product series is based on the Cascades™ actively, water-cooled, low thermal resistance package, which provides end users with state-of-the-art power, brightness and reliability. Our 1-cm wide, MOCVD grown GaAs or InP arrays consist of multiple transverse mode emitters, which provide low beam divergence and narrow spectral bandwidth. Cascades™ vertical stacked arrays are available in a wide range of wavelengths between 790 nm to 980 nm, and 1400 to 1600 nm.

The design of these devices allows multiple packages to be vertically stacked, with a pitch of 1.8 mm, up to 20 bars high. Standard packaging footprint allows these stacks to easily integrate into your product.

Features

- Highest power
- High reliability
- Low bar smile
- Fast-axis lensing
- High polarization purity

Applications

- Solid-state laser pumping
- Materials processing
- Medical therapeutics

Typical Device Performance

Package	VSA-ww-xxx-yyyy ¹					
Optical						
Center Wavelength (Range) ¹	nm	790-825	910-980	1400-1600	790-825	910-980
Center Wavelength Tolerance	nm	± 3	± 3	± 5	± 3	± 3
Number of Bars	#	20-Jan	20-Jan	20-Jan	20-Jan	20-Jan
CW Output Power / Bar	W	60	60	25	100	80
Bar Length	cm	1	1	1	1	1
Number of Emitters / Bar	#	49	49	19	64	49
Emitter Size	µm	100	100	100	120	100
Emitter Spacing	µm	200	200	500	150	200
Spectral Width (FWHM)	nm	< 3	< 4	< 10	< 3	< 4
Slope Efficiency	W / A	> 1.1	> 0.9	> 0.4	> 1.05	> 0.9
Polarization	TM or TE	TM	TE	TE	TM	TE

Proven Performance

Fast-axis Divergence	Degrees	36°	38°	27°	36°	38°
Fast-axis Divergence (Lensed)	Degrees	0.25°	0.25°	0.25°	0.25°	0.25°
Slow-axis Divergence	Degrees	10°	10°	10°	10°	10°
Wavelength Temperature Coefficient ¹	nm / °C	0.28	0.3	0.4	0.28	0.3
Electrical						
Power Conversion Efficiency	%	55	50	30	48	52
Threshold Current (I _{TH})	A	14	8	10	26	12
Operating Current (I _{OP})	A	60	70	70	110	95
Operating Voltage / Bar (V _{OP})	V	1.8	1.6	1.2	1.85	1.6
Series Resistance / Bar (R _S)	Ω	0.005	0.005	0.005	0.005	0.005
Mechanical						
Storage Temperature Range ³	°C	10 to 40	10 to 40	10 to 40	10 to 40	10 to 40
Thermal						
Thermal Resistance ²	°C / W	0.35	0.35	0.35	0.35	0.35
Operating Temperature	°C	20 to 35	20 to 35	20 to 35	20 to 35	20 to 35
Fluid Flow Rate	ml/min/plate	200-250	200-250	200-250	200-250	200-250
Max Inlet Pressure	psi	55	55	55	55	55
Inlet to Outlet Pressure Drop	psi				35	35
Deionized Water Resistivity	MΩ - cm	0.25-0.5	0.25-0.5	0.25-0.5	0.25-0.5	0.25-0.5
Filter	μm	< 20	< 20	< 20	< 20	< 20

¹ VSA-ww-xxx-yyy: ww denotes the number of bars in the stack; xxx denotes CW power; yyy denotes the operating wavelength.

² The wavelength temperature coefficient is the wavelength shift per °C change at the diode junction.

³ A non-condensing environment is required for storage and operation below ambient dew point.

⁴ Thermal resistance is the diode junction temperature shift per incremental Watt of heat load.

CFR Regulation

These components do not comply with the federal regulation (Title 21 CFR, Chapter 1, Subchapter J) as administered by the Center for Device and Radiological Health. Purchaser acknowledges that their products must comply with these regulations before they can be sold to an end-user.

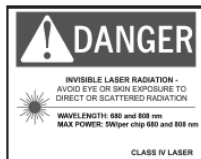

Notice

nLIGHT continually improves its products to provide our customers with outstanding quality and reliability. nLIGHT may make changes to specifications and product descriptions at any time, without notice. In addition, nLIGHT offers a limited warranty to ensure customer satisfaction. For complete details, please contact your nLIGHT sales representative.

Copyright © 2008 nLIGHT. All rights reserved.

Package Dimensions

Cascades™ Vertical Stacked Arrays 10 bar, unlensed

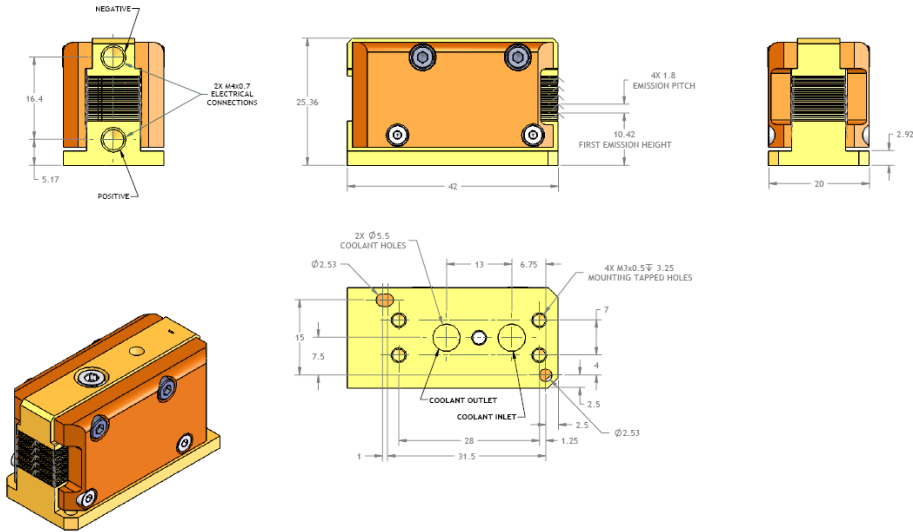

Cascades™ Vertical Stacked Arrays 10 bar, lensed

