

Item Description **e06-06-070-0969-1-200-0.22-SI-FPT-2.0-HT-VBG**  
 Model **e06.0700969200**

ECCN: 6A005.d.1.b.1 <sup>4</sup>

	Units	Lower Spec	Typical	Upper Spec
<b>Optical</b>				
CW Output Power (in fiber)	W		70	
CW Output Power (as measured)	W	60	68	
Wavelength Peak	nm	968.0	969.0	970.0
Spectral Width (FWHM)	nm			1.0
NA within 95% Power Enclosure	-		0.13	
Fiber Core / Clad Diameter	µm		200 / 220	
Fiber NA / Index Type	-		0.22 NA / Step Index	
Back Reflection Isolation 1060 - 1200nm	dB	15		
<b>Electrical</b>				
Electrical-to-Optical Efficiency	%		45	
Threshold Current	A		0.6	
Operating Current	A		15.5	15.5
Operating Voltage	V		10.0	10.5
Wavelength Stabilized Operating Current <sup>5</sup>	A	12		17
<b>Mechanical</b>				
Mass	g		85	
Fiber Length	m	1.5	2.0	
Active Fiber Bend Radius	mm	35		
Fiber Jacketing	-		900 µm Hytrel Loose Tube Buffer	
Fiber Termination	-		FPT	
<b>Thermal</b>				
Waste Heat	W		85	
Operating (Housing) Temperature <sup>2,3</sup>	°C		+30	
Wavelength Temperature Coefficient	nm / °C		0.01	

**Outline Drawing (Package Dimension 46 x 45 x 11.1 mm)**

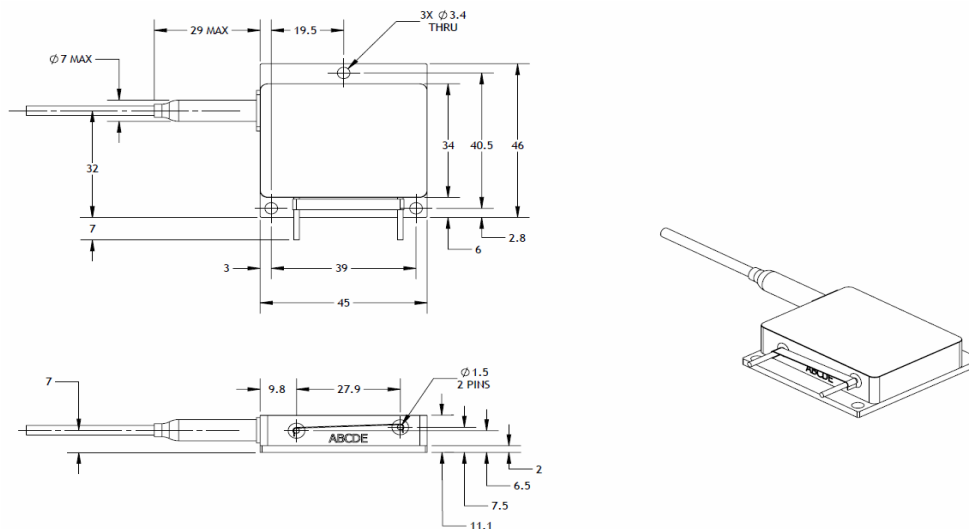

**Notes**

- 1 Production specification shown are for beginning of life performance. End of life operating current (Iop) is 110% beginning of life Iop.
- 2 A non-condensing environment is required for operation and storage. Storage conditions are from -20 to +70 °C with relative humidity between 5 to 85 %.
- 3 Operating temperature defined by the package housing.
- 4 Export Control Classification Number (ECCN) as defined by the Export Administration Regulations (EAR).
- 5 Wavelength stabilized to >95 % power in band of 967.5 nm to 970.5 nm at the rated operating temperature.

This product is not certified in accordance with IEC 60825-1 or 21CFR1040.10/ 21CFR1040.11 and is solely intended to be integrated into a laser product certified by the Purchaser. The Purchaser acknowledges that their product (incorporating the nLIGHT laser product) must comply with the applicable regulations before it can be sold.



**Notice**  
 nLIGHT continually improves its products to provide customers with outstanding quality and reliability, therefore may change certain specifications and product descriptions at any time, without notice. Additionally, nLIGHT offers a limited warranty to ensure customer satisfaction. For complete details, please contact an nLIGHT sales representative.



nLight Corporation  
 5408 NE 88th Street, Bldg E  
 Vancouver, Washington 98665  
 United States of America  
 Phone: 866.202.4488