

Item Number 1062714
 Item Description e18-12-103-0976-3-105-0.22-SI-FPT-2.0-HT
 Model e18.1030976105

Design Validation (Beta)⁴
 ECCN: EAR99⁵

| | Units | Lower Spec | Typical | Upper Spec |
|--|---------|------------|---------------------------------|------------|
| Optical | | | | |
| CW Output Power (with fresnel loss) ⁶ | W | 87 | 103 | |
| CW Output Power (without fresnel loss) | W | | 107 | |
| Centroid Wavelength | nm | 973.0 | 976.0 | 979.0 |
| Spectral Width (FWHM) | nm | | 4.7 | 7.0 |
| Power within 0.14 NA | % | 90 | | |
| Fiber Core / Clad Diameter | µm | | 105 / 125 | |
| Fiber NA / Index Type | - | | 0.22 NA / Step Index | |
| Electrical | | | | |
| Electrical-to-Optical Efficiency | % | 33 | 40 | |
| Threshold Current | A | | 0.4 | |
| Operating Current | A | | 12.0 | 12.0 |
| Operating Voltage | V | | 21.3 | 22.4 |
| Mechanical | | | | |
| Mass | g | | 450 | |
| Fiber Length | m | 1.5 | 2 | |
| Active Fiber Bend Radius | mm | 25 | | |
| Fiber Jacketing | - | | 900 um Hytrel Loose Tube Buffer | |
| Fiber Termination | - | | FPT | |
| Thermal | | | | |
| Thermal Resistance | °C / W | | 0.3 | |
| Waste Heat | W | | 153 | |
| Operating (Housing) Temperature ^{2,3} | °C | | +27 | |
| Wavelength Temperature Coefficient | nm / °C | | 0.35 | |
| Wavelength Current Coefficient | nm / A | | 1.2 | |

Outline Drawing (Package Dimension 97 x 76 x 14 mm)

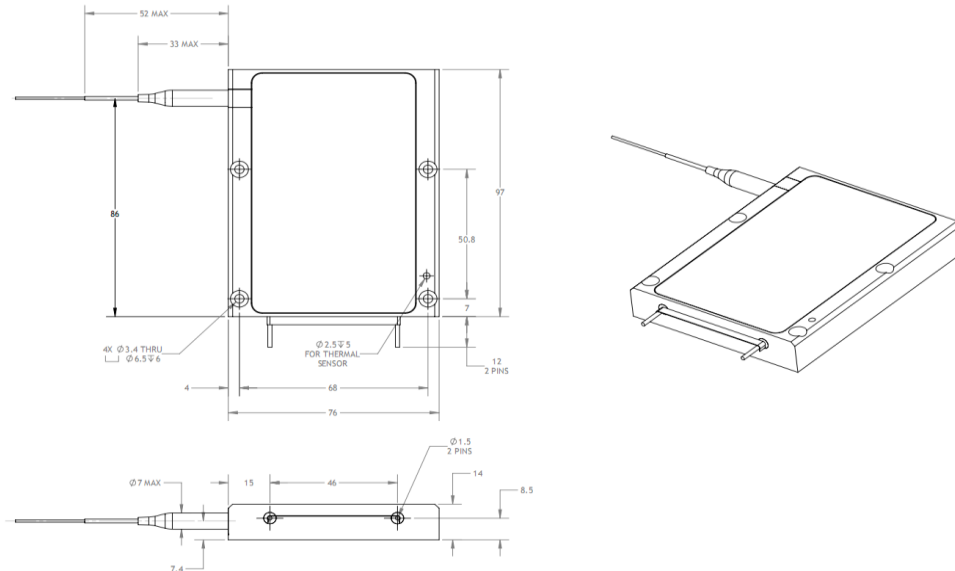

Notes

- ¹Production specification shown are for beginning of life performance, end of life operating current (Iop) is 120% beginning of life Iop
- ²A non-condensing environment is required for operation and storage. Storage conditions are from -20 to +70 °C with relative humidity between 5 to 85 %
- ³Operating temperature defined by the package housing. Acceptable operating range is 20 - 35C, but performance may vary.
- ⁴Current phase within the nLIGHT's NPI (New Production Introduction) Process
- ⁵Export Control Classification Number (ECCN) as defined by the Export Administration Regulations (EAR)
- ⁶Reported power is with an uncoated distal fiber end, therefore will be ~ 3.5 % higher if spliced



Notice
 nLIGHT continually improves its products to provide customers with outstanding quality and reliability, therefore may change certain specifications and product descriptions at any time, without notice. Additionally, nLIGHT offers a limited warranty to ensure customer satisfaction. For complete details, please contact an nLIGHT sales representative.



nLight Corporation
 5408 NE 88th Street, Bldg E
 Vancouver, Washington 98665
 United States of America
 Phone: 866.202.4488
 360.566.4460
 Fax: 360.546.1960
 e-mail: sales@nlight.net
 web: www.nlight.net

This product is not certified in accordance with IEC 60825-1 or 21CFR1040.10/21CFR1040.11 and is solely intended to be integrated into a laser product certified by the Purchaser. The Purchaser acknowledges that their product (incorporating the nLIGHT laser product) must comply with the applicable regulations before it can be sold.