



The Pearl™ P16 is designed for Material Processing to optimize the demanding industrial requirements of continuous performance with ease of integration.

These pump lasers use a revolutionary fiber technology, PowerCore™, which delivers high-brightness, Gaussian or top-hat pump profiles to maximize overlap with the TEM₀₀ cavity mode for efficient brightness conversion to 1 μm. The industry-leading efficiency of these pump sources is enabling compactness, reliability and simplified cooling for the next generation of solid-state laser systems. Pearl's embedded nXLT™ single-emitter technology is resetting the benchmark for high-brightness semiconductor laser reliability.

Features

- Patented nXLT™ diode protection for extended life
- Low-current, fault-tolerant architecture
- Industry-leading wall-plug efficiency >50%
- Field-replaceable, PowerCore™ mode-stable fiber
- Plug and play compatibility with nLIGHT's DL system
- Electrically isolated housing

Applications

- Rod Pumping
- Disk Pumping
- Slab Pumping

Proven Performance

Typical Device Performance

Package		P16		
Optical				
Wavelength	nm	900-990 nm		
Wavelength tolerance	nm	± 10		
CW output power	W	95	110	130
Fiber core diameter	µm	200 or 400		
Beam divergence	NA ¹	0.17		
Fiber length (standard)	m	2.0		
Electrical				
Power conversion efficiency (typical)	%	52		
Operating current (typical)	A	9.0		
Operating voltage (typical)	V	20.4	23.8	27.2
Mechanical				
Storage temperature range ²	°C	-40 to +80		
Mass	gr	220		
Thermal				
Operating temperature ²	°C	+15 to +25		
Accessories				
Line Generator Optic Modules				
Collimator and Spot Generator Optic Modules				
Monitor Photo Diode				
PPS™ OEM Diode Controller				
Turn-Key System				

¹ Numerical aperture (NA) is the sine of the half-angle encircling 90% of the optical energy from the fiber.

² A non-condensing environment is required for storage and operation.

Package Dimensions

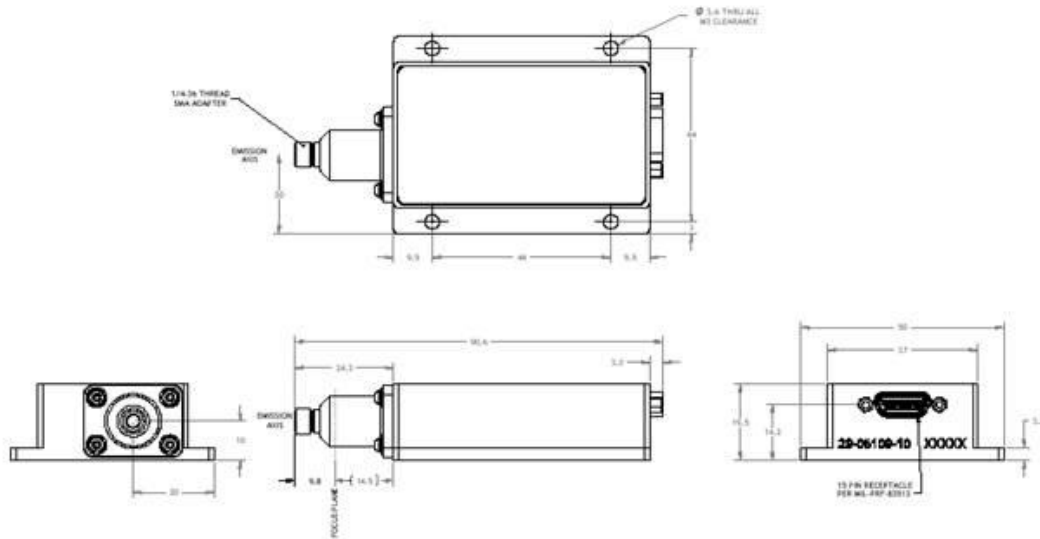

CFR Regulation

These components do not comply with the federal regulation (Title 21 CFR, Chapter 1, Subchapter J) as administered by the Center for Device and radiological Health. Purchaser acknowledges that their products must comply with these regulations before they can be sold to an end-use.

Copyright © 2008 nLIGHT. All rights reserved.

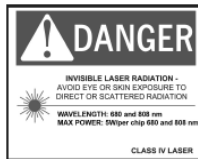

Notice

nLIGHT continually improves its products to provide our customers with outstanding quality and reliability. nLIGHT may make changes to specifications and product descriptions at any time, without notice. In addition, nLIGHT offers a limited warranty to ensure customer satisfaction. For complete details, please contact your nLIGHT sales representative.